

Proper Semen Handling Improves Conception Rates of Dairy Cows

Cooperative Extension Service
College of Agriculture and
Home Economics



Guide D-303

Michael Looper, Extension Dairy Specialist

This publication is scheduled to be updated and reissued 9/05.

Artificial insemination (AI) has greatly enhanced production potential in the dairy industry since its implementation in the United States in the late 1930s (Cole, 1938). However, improper semen handling can result in low conception rates, minimizing the advantages of an AI program. Semen is most frequently damaged during handling after thawing and prior to insemination of the cow. The following practices should help minimize semen damage that occurs due to improper handling procedures.

Caring for Insemination Equipment

Several items are necessary to perform successful artificial insemination, including an AI gun, plastic sheaths, shoulder-length gloves, straw cutter, thermometer, thaw box, tweezers, paper towels, and lubricant. Plastic or stainless steel boxes are good containers in which to keep equipment clean and dry. Clean equipment after each use with 70 percent isopropyl alcohol to prevent spread of disease. Disinfectants and soaps

are lethal to semen and should not be used as lubricants or to clean equipment.

Removing Semen from the Liquid Nitrogen Tank

Time spent removing semen from the liquid nitrogen (LN) tank must be kept to a minimum to reduce semen damage. Temperatures can reach +54°F in the neck of the LN tank (1 inch from the top) (Saacke, 1974; fig. 1). If the entire canister of semen (10 straws) is withdrawn above the frost line (2 to 3 inches from the top of the tank), all straws of semen can be damaged. When the desired straw of semen cannot be located within 10 seconds of raising the canister, lower the canister back into the LN for 10 to 15 seconds to cool completely. Remove semen from the tank with tweezers, *not* with the hands. Note the location of the semen in the tank before removing the plug from the tank. This can be accomplished by maintaining a tank inventory with a wall chart or inventory wheel (fig. 2). Quantity of semen re-

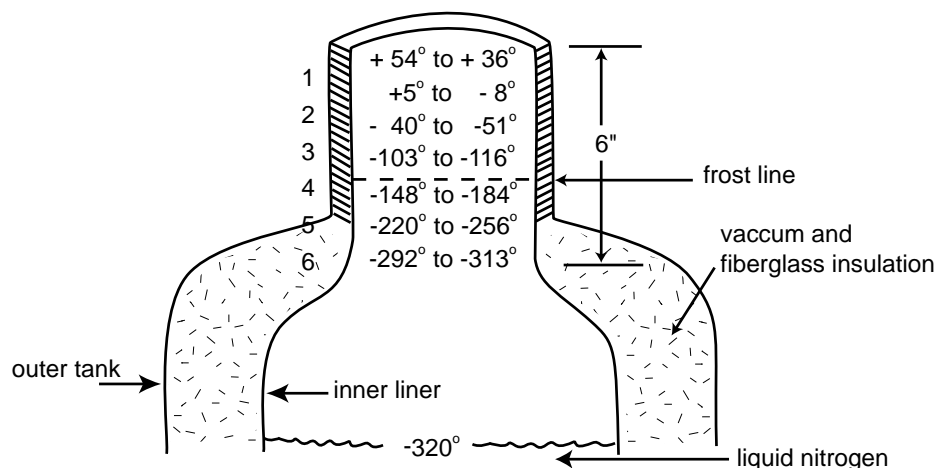

Figure 1. Temperatures found in the neck of a semen tank. Adapted from Saacke, 1974.

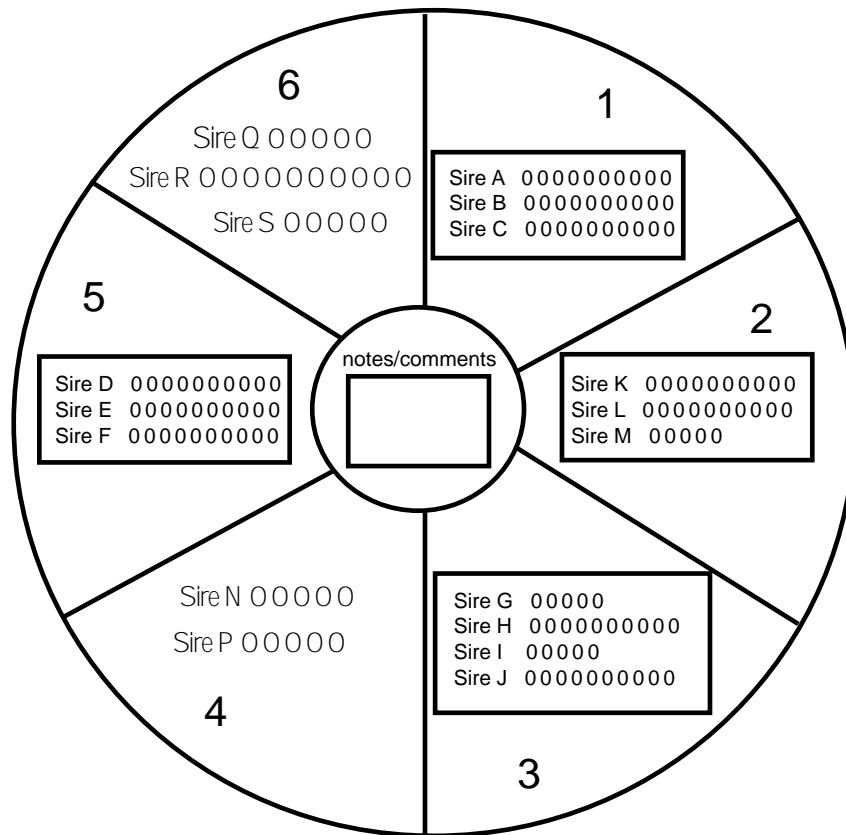

Figure 2. Semen inventory wheel made from Plexiglas or laminated cardboard. Sire number can be written on adhesive labels and attached to the wheel or written directly on the wheel with erasable markers. Circles represent straws of semen and can be darkened after each straw is used (adapted from Senger, 1992).

maining in the LN tank also can be accounted for with such a system.

Thawing Semen

Unfortunately, recommended procedures for thawing semen are not the same for all AI companies. Dairy producers usually use semen from several companies but use only one protocol for thawing semen. The National Association of Animal Breeders (NAAB) recommends thawing semen at about 90° to 95°F for at least 40 seconds (Herman and Madden, 1987). Thawing semen between these temperatures allows more semen to survive the thawing process. Calibrate the thermometers used for monitoring thaw water temperature on a regular basis to insure accuracy of temperature measurements. Never thaw semen straws in your pocket or in the cow. Under these conditions, thaw rates are too slow and will re-

duce the number of viable sperm cells. Completely dry the semen straw with a paper towel after thawing because water is lethal to sperm cells.

In large herds, it is not uncommon for several cows to exhibit estrus on the same day, so it is likely that numerous straws of semen will be thawed at one time. Researchers at Washington State University (Brown et al., 1991) reported that as many as 15 to 20 straws of semen can be thawed simultaneously in a thermos without reducing semen quality (fig. 3). However, the inner semen straws of a group of straws that had frozen together demonstrated reduced motility, suggesting the thaw water should be agitated so that straws do not freeze together during thawing. A larger volume of water (more than 1 quart) is recommended if more than five straws of semen are thawed simultaneously (DeJarnette, 1999). The number of straws of semen thawed should not exceed the quantity that can be used within 10 to 15 minutes.

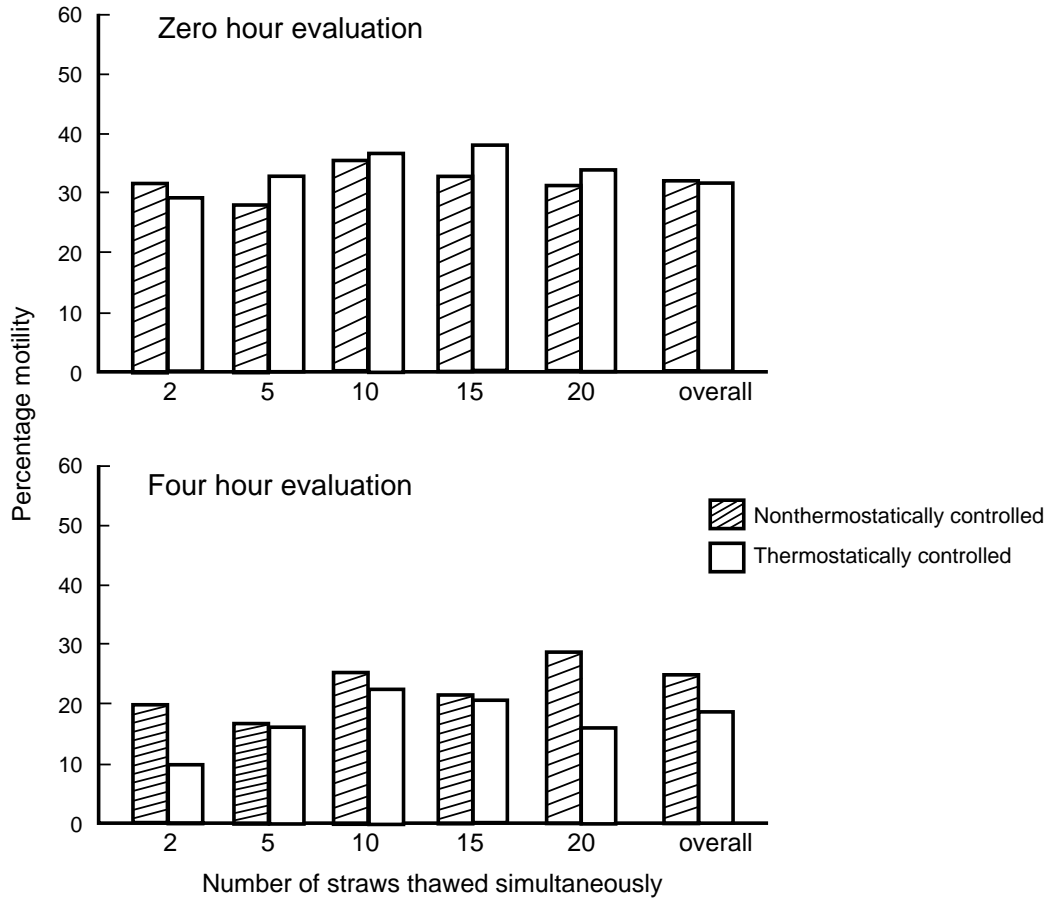

Figure 3. Effect of thawing groups of straws and type of thawing bath on percentage of sperm motility 0 hours and 4 hours after thawing at 97°F. Thawing semen in groups did not significantly damage sperm cells (adapted from Brown et al., 1991).

Loading the AI Gun

Before loading the semen in the AI gun, warm the gun by rubbing it with a paper towel to avoid cold-shocking the semen (ABS Global, 1996). Cut the semen straw at the crimped end, not at the end with the cotton plug. Then place a plastic sheath over the semen and gun. Place the semen gun close to your body under clothing (such as a shirt or jacket) to avoid cold-shocking semen.

A preliminary study from Hawaii (Lee et al., 1997) indicates loading multiple AI guns may be detrimental to conception rates in hot environments. In this study, four cows were bred in about 6 minutes. Cows bred last (at 6 minutes) had lower conception rates than cows bred first, second, and third (fig. 4). It should be noted that these conception rates were not statistically different. Further research with more cows is needed

to confirm effects on conception rates of time from thawing to insemination. It still is recommended that cows be inseminated as soon as possible after thawing semen.

Proper Semen Handling on Large Dairy Operations

On large operations, dairy personnel not acquainted with AI techniques sometimes are recruited to help inseminate cows. But only people who have been adequately trained in artificial insemination should be allowed to breed cows. Untrained personnel can become fatigued, reducing the accuracy of semen deposition.

General recommendations include thawing semen at 95°F in a water bath, not in the pocket or cow, for at least 30 seconds but not more than 15 minutes. If several straws of semen are thawed at

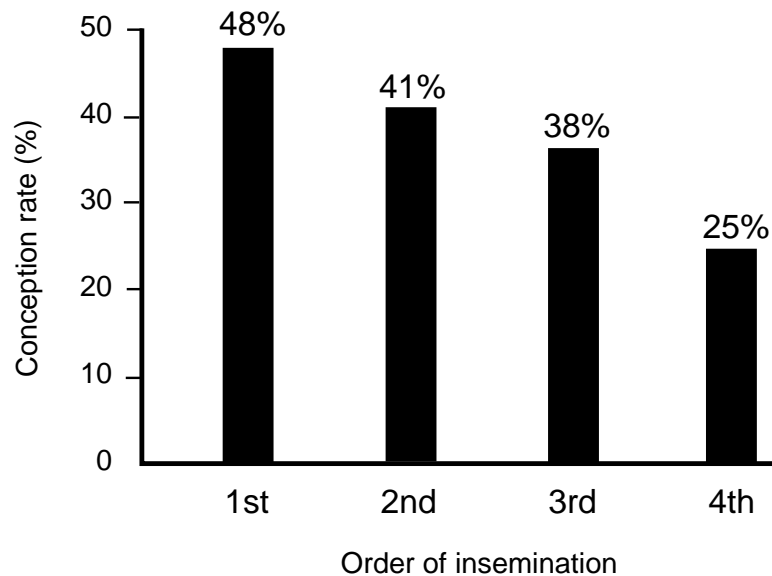

Figure 4. Conception rates of cows decrease with order of insemination (Lee et al., 1997).

one time, stir the water bath so that straws do not freeze together. Use the same caution when thawing several straws of semen as you would when thawing a single straw.

Do not load too many AI guns simultaneously. Conception rates could be reduced.

Inseminate cows as soon as possible after semen is thawed. Dairies using lock-up stanchions should develop some form of an AI cart or wagon. A golf cart or other small vehicle (such as a mail truck) can be used to transport the AI equipment to the cow. This will allow less time between removing the semen from the thaw bath and inseminating the cow.

Artificial insemination techniques of people responsible for breeding cows should be reevaluated on a regular basis (such as monthly or quarterly). It is important to remember that proper AI techniques must not be compromised for convenience.

LITERATURE CITED

ABS Global. 1996. A.I. Management Manual. ABS Global, Inc. (ed.). DeForest, WI.

Brown, D.W., Jr., P.L. Senger, and W.C. Becker. 1991. Effect of group thawing on post-thaw viability of bovine spermatozoa packaged in .5-milliliter French straws. *J. Anim. Sci.* 69:2303-2309.

Cole, C.L. 1938. Artificial insemination of dairy cattle. *J. Dairy Sci.* 21:131-132. (Abstr.).

DeJarnette, M. 1999. How many straws should you thaw at once? *Select Sires Selections*. pp. 8-9.

Herman, H.A., and F.W. Madden. 1987. *The Artificial Insemination and Embryo Transfer of Dairy and Beef Cattle* (7th ed.). Interstate Printers and Publishers, Inc., Danville, IL.

Lee, C.N., T.Z. Huang, and A.B. Sagayaga. 1997. Conception rate in dairy cattle is affected by the number of semen straws thawed for breeding. *J. Dairy Sci.* 80 (Suppl 1): 151.

Saacke, R.G. 1974. Concepts in semen packaging and use. *Proc. Eighth NAAB Conf. on Artif. Insem. Beef Cattle*. pp.11-19.

Senger, P.L. 1992. Handling frozen semen. In: H.H. Van Horn and C.J. Wilcox (eds.). *Large Dairy Herd Management*. pp. 110-115. American Dairy Science Association, Champaign, IL.